

**Request for Continued Participation in the  
Midwest States Pooled Fund  
to Advance Roadside Safety Research**

**Project Champion & WYDOT Project Manager:**

Bill Wilson, P.E. Standards Engineer  
Wyoming Dept. of Transportation  
5300 Bishop Blvd.  
Cheyenne, WY, 82009

**Lead Pooled Fund Administrator:**

Jodi Gibson  
Materials and Research  
Nebraska Department of Roads

**Principal Investigator:**

Ronald Faller, Director, et al.  
Midwest Roadside Safety Facility  
130 Whittier Research Center  
2200 Vine Street  
Lincoln, Nebraska 68583-0853

**Submitted to:**

The WYDOT Research Advisory Committee  
September 18, 2015



## **Problem Statement:**

Over fifty percent of the fatalities on our nation's highways are the result of lane departure crashes where the vehicle left the roadway. In Wyoming the figure is over seventy five percent. While reductions have been made in serious injury and fatalities over the last seven years, it is still at a level too high to tolerate. In 2013, nearly 33,000 motor vehicle fatalities occurred nationally. For individuals age 4 and 16-24, motor vehicle fatalities are the leading cause of death in the U.S. Nationally, the number of vehicle miles driven began to plateau in 2008 with the downturn in the economy, however, it is predicted travel will begin to surge upward in the future, and with it, the concern that fatalities will again begin to rise. AASHTO's Standing Committee on Highways has included in their strategic plan, the objective of reducing fatalities in half by 2030. WYDOT's Mission Statement is to "provide a safe, high quality and efficient transportation system," and within that, one of the goals is to, "improve safety on the state transportation system." There is a significant need to develop better roadside safety devices and more cost effective design strategies to reduce serious injury and fatal crashes, particularly in this environment where funding shortfalls have nearly decimated major infrastructure improvements.

In an effort to combat the carnage occurring on our nation's roadsides, three states thought about the efficiencies that could be gained by pooling a portion of their federal research funds to attempt to solve common roadside safety problems. The Midwest States Pooled Fund was formed. Midwest Roadside Safety Facility, related closely to the University of Nebraska, was to be their research team. As accomplishments of the Pooled Fund began to get noticed, more states began joining. Today, there are twelve member states including Wyoming. The Pooled Fund is performing some of the most beneficial research leading to the advancement of roadside safety. Research performed by the Pooled Fund is always relevant since all of the problem statements come from real world situations encountered by the member states. The Research Advisory Committee has previously approved three year commitments of funding to ensure continuity in the program and its projects. Therefore, it is requested to fund WYDOT's participation at the current level of \$65,000 per year for the next three years.

## **Background:**

The cost of roadside safety research can be quite expensive. Full scale crash testing costs over \$50,000 per test. Data collection for statistical and cost-benefit studies can also be expensive. Many states share similar roadside safety issues; therefore it makes sense to pool resources to obtain effective solutions. The Midwest States Pooled Fund was the first to take advantage of this cost sharing approach for roadside safety. The Pooled Fund continues to contract with Midwest Roadside Safety Facility (MwRSF) in Lincoln, Nebraska as their principal investigators. MwRSF has become one of the world's leaders in roadside safety research and innovation. Accomplishments by the staff at MwRSF outside of Pooled Fund efforts include the development of many guardrail terminals, improvements to computer simulation programs, development of crash testing standards, etc. One of their more interesting accomplishments was the development of the "Safer Barrier," an energy absorbing barrier developed for NASCAR after Dale Earnhardt was killed in a racing crash. It is now deployed on the outside wall of every NASCAR track and soon to be on the inside walls as well.

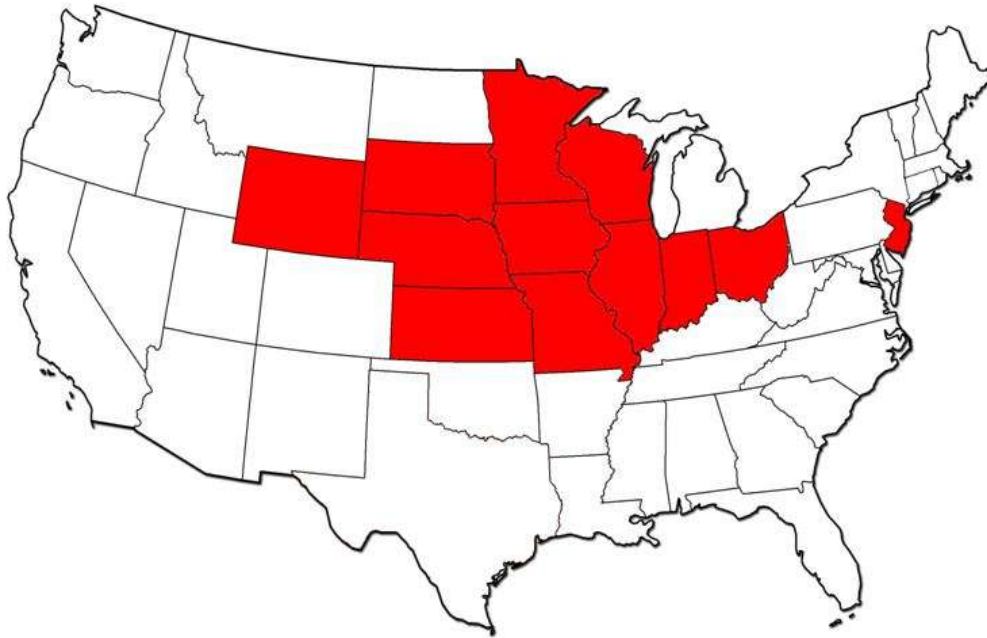

Current Member States of the Pooled Fund

The Pooled Fund has been so successful it has grown to twelve member states. Still, they have not had enough resources to tackle all of the issues in roadside safety, so a second pooled fund called the TTI Pooled Fund was created a few years ago to help fill the gap for projects which couldn't be funded by the Midwest States Pooled Fund. Wyoming joined the Midwest States Pooled Fund several years ago, and has reaped several benefits from participation, including improved procedures and devices now incorporated in design procedures, standard plans, special details, etc. which in turn are making our highway system safer. The Pooled Fund has also funded a special ongoing project to make the expert staff of Midwest Roadside Safety Facility available to individual states to help solve unique problems which wouldn't warrant a research project. Those problems are posted on Midwest's website for Q&A's (<http://mwrsf-qa.unl.edu/>) so all states can benefit from the solutions provided by Midwest's researchers. MwRSF makes all of their reports and crash tests videos available to the member states (unless a client has specifically requested their project remain privileged). The videos constitute a special resource for training DOT personnel.

Every year, the state representatives of the member states submit problem statements for work in the upcoming year(s). The staff of MwRSF provide assistance to the state representatives in preparing problem statements. In April, the representatives meet in Lincoln to vote on the priority of the problems statements since there are not enough funds to cover every problem statement. Wyoming has been fortunate to have many of their proposals accepted by the Pooled Fund. Because the problem statements come from DOT practitioners, it assures implementation of the research. At the end of each research project, a bound report is issued following the format dictated by federal research standards which fully documents the research effort. Each member state receives pdf and hard copies as well as crash test videos if crash testing is part of the project. Many projects are of national interest so the researchers may also prepare a paper for

presentation at the Transportation Research Board (TRB) Annual Meeting. Many of those have won a best paper award.

### **Recent Pooled Fund Accomplishments Ready for WYDOT Implementation:**

**1. Midwest Guardrail System (MGS) and ancillary options. MGS guardrail represents a significant advancement in performance for corrugated beam guardrail.** Although the two systems use the same w-beam rail elements (with a different hole punching) and the same post, MGS is mounted at 31 inches versus 27 inches, has splices moved to mid-span, and typically uses a deeper blockout. It has recently been discovered that when using w-beam's original mounting height of 27 inches, it doesn't pass either the older NCHRP 350 or the new MASH crashworthy standards. MGS passes both standards.

Some of the advantages demonstrated with the MGS over w-beam are:

- Standard redirection tests show impacting vehicles are far more stable
- Testing has shown far less susceptibility to guardrail ruptures
- MGS can safely contain and redirect vehicles with higher centers of gravity
- MGS has a greater mounting height tolerance
- With a higher mounting height, it should have less propensity to drift snow
- MGS is more forgiving on superelevated roadways since it has better impact height tolerances
- With a higher mounting height, it can accommodate future pavement overlays without needing to adjust the rail height



Comparison of W-beam (left) and MGS in a MASH Crash Test

### Additional ancillary options developed and crash tested for MGS:

- Placement with a six inch curb in front of the standard run
- Placement up to four feet down on a 1V:8H slope
- Special design for placement of posts in pavement and rock
- Special design for placement with a free span (no posts) up to 24 feet over box culverts with little cover

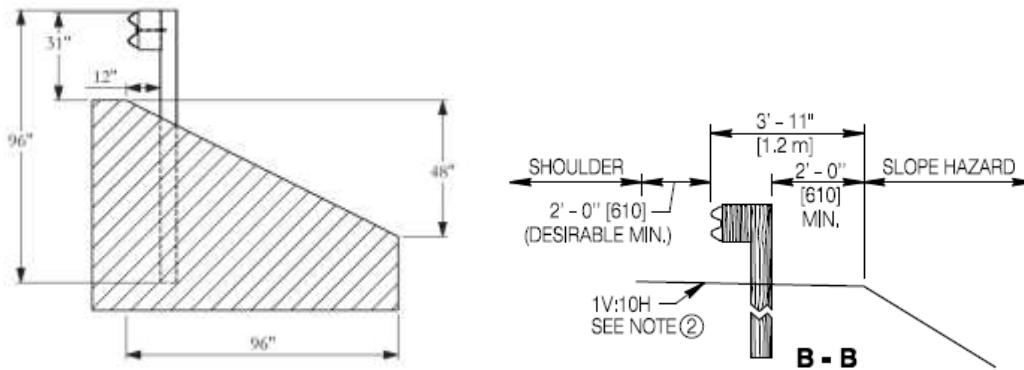

- Special design for placement directly in front of a steep slope using longer posts (doesn't require 2 feet of flat slope behind the guardrail posts) see below:

WYDOT has now implemented MGS including these new ancillary options with two new standard plans. Construction of MGS installations on Wyoming highways began in 2014.

**2. Portable concrete barrier anchored to a bridge deck.** Portable concrete barriers can deflect up to around four feet when impacted. These barriers have the potential to fall off a bridge deck (or other drop-off) if placed too closely to the edge of the deck. Such a case happened recently in Washington State where the barrier fell to the road underneath it, killing the occupants of an SUV. The Pooled Fund has developed an anchoring system and transition section to anchor portable concrete barriers to a bridge deck so they won't deflect and fall off the deck. A new standard plan is being prepared to show the necessary details.

**3. MGS low cost bridge rail and culvert side mount rail.** The Pooled Fund developed and tested a low cost bridge rail system incorporating sockets mounted to the edge of a bridge deck with posts inserted into the sockets and w-beam rail attached directly without the use of blockouts. The w-beam is mounted at the same height as the MGS approach rail and does not require an approach guardrail transition. Repairs are made simple by removing the old post from their sockets, installing new posts, and replacing the rail. The system performed very well in the crash tests.





The MGS Bridge Rail Performed Quite Well in High Speed Redirection Crash Tests.

This system is currently being constructed on a box culvert over St. Mary's Creek in District I, where the existing railing is substandard, and there was not enough fill to embed guardrail posts over the top of the box.

Another application of the Low Cost Midwest Bridge Rail System came about through a question submitted to the Pooled Fund about using this system to replace a substandard railing on a timber bridge in District I. The rail mounting height was much too low and the posts too weak to support the rail if impacted. There was concern that a stiffer railing system would





system on median slopes. No criteria had ever been established for crash testing in conjunction with median slopes. Researchers had to analyze the various trajectories and bumper heights for various vehicles as they depart the roadway, traverse the median and cross the ditch. The test matrix has now been resolved and will be added to the forthcoming update to MASH (Manual for Assessing Safety Hardware). Other problems have delayed this project as well, but it is now on track and hopefully will result in an approved system. A terminal for this system is also in the developmental stages.



Early Testing of the MGS High Tension, Non-Proprietary Cable Guardrail

**2. Extension of the MGS Long Span for Box Culverts.** Currently, the Pooled Fund has a design for MGS spanning 24 feet (without posts). This is typically used for box culverts with little cover and where guardrail posts cannot get their full embedment depth. The Pooled Fund members saw a need to omit one more post to account for the typical width of most box culverts. The first crash tests have gone well and MwRSF should be conducting the final two tests in the near future.



The Pooled Fund Seeks to Expand the Length of the Free Span of the MGS Long Span

**3. Standard MGS with one post omitted.** Sometimes guardrail installations must cross drainage or other features where one post must be omitted. Recent full scale crash testing for this project has confirmed that one post can be omitted without any special treatment. We are awaiting the final report and FHWA concurrence.



**4. Development of a socketed top mount system for MGS on low fill culverts with spans longer than 24 feet.** There are still many box culverts with little cover on top where the span exceeds what the MGS long span can accommodate. Currently, posts have to be welded to an end plate that is bolted onto the top of the box culvert. If the posts are impacted, maintenance has to dig down to the top of the box culvert and replace the posts. This project will attempt to adapt the MGS Low Cost Bridge Rail System and place sockets mounted to the box culvert and flush with the grade on top. When the rail is impacted, the posts are pulled out of the sockets and new ones inserted.

**5. Preliminary feasibility study for the development of a non-proprietary guardrail terminal for MGS.** All crashworthy guardrail terminals for w-beam and MGS rail are proprietary and therefore must be competitively bid. This study looks at the feasibility (and cost) to develop a non-proprietary terminal for MGS. This may also address some of the concerns recently raised about the Trinity ET-Plus guardrail terminal.

**Conclusion:**

The summary presented above represents many, but not all of the pooled fund efforts. Wyoming has benefitted greatly by membership in the pooled fund. It would be difficult to put a price tag on the value of the technology transfer provided through participation in the pool fund. It has permitted the Standard Plans Section of Engineering Services to provide extensive support to designers and field personnel in the area of roadside safety. Likewise, Wyoming has been able to voice our knowledge and concerns to researchers to help improve the quality of research and the maintainability of roadside safety devices. Many of the features developed through the pooled fund will become apparent on Wyoming's highways, adding to the safety and efficiency of our system. Several projects proposed by Wyoming have been selected by the Pooled Fund for pursuit. We therefore respectfully request continued support of the pooled funds efforts and request funding for the next three years at \$65,000 per year.

Appendix A. Reports Issued by MwRSF back to 2011 (Those with the MwSPF designator are projects sponsored by the Pooled Fund.)

TRP-03-249-11	NA	2009	2011-11	Wisc	Y	CRASH TESTING OF VARIOUS EROSION CONTROL FEATURES - PHASE I: PRELIMINARY GUIDELINES
TRP-03-213-11	4CMB-1--3	2003	2011-12	MwSPF	Y	PHASE I DEVELOPMENT OF A NON-PROPRIETARY, FOUR-CABLE, HIGH TENSION MEDIAN BARRIER
TRP-03-251-11	NA	2010	2011-12	Wisc	Y	ROADSIDE GRADING GUIDANCE - PHASE I
TRP-03-259-11	NA	2005	2011-12	MwSPF	Y	EVALUATION OF THE IN-SERVICE SAFETY PERFORMANCE OF SAFETY-SHAPE AND VERTICAL CONCRETE BARRIERS
TRP-03-232-11			2012-02	MATC	N	DEVELOPMENT OF A SOCKETED FOUNDATION FOR CABLE BARRIER POSTS - PHASE I
TRP-03-252-12	NA	2010	2012-03	Wisc	Y	SYNTHESIS OF CRASH CUSHION GUIDANCE
TRP-03-253-12	4CMB-4, 5	2010	2012-03	MwSPF	Y	PHASE II DEVELOPMENT OF A NON-PROPRIETARY, FOUR-CABLE, HIGH TENSION MEDIAN BARRIER
TRP-03-255-12	4MGSMRH-1,2	2010	2012-03	MwSPF	Y	DETERMINATION OF THE MAXIMUM MGS MOUNTING HEIGHT - PHASE I CRASH TESTING
TRP-03-267-12		2010	2012-05	MATC	Y	IMPROVED MODELS OF CABLE-TO-POST ATTACHMENTS FOR HIGH-TENSION CABLE BARRIERS
TRP-03-265-12	NA	2011	2012-07	MwSPF	Y	TEST MATRICES FOR EVALUATING CABLE MEDIAN BARRIERS PLACED IN V-DITCHES
TRP-03-268-12	NA	2010	2012-07	MwSPF	Y	DEVELOPMENT AND RECOMMENDATIONS FOR A NON-PROPRIETARY, HIGH-TENSION, CABLE END TERMINAL SYSTEM
TRP-03-266-12	NA	2010	2012-08	Wisc	Y	SAFETY INVESTIGATION AND GUIDANCE FOR RETROFITTING EXISTING APPROACH GUARDRAIL TERMINALS
TRP-03-285-13		2011	2012-08	MwSPF	Y	DESIGN OF CABLE-TO-POST ATTACHMENTS FOR USE IN A NON-PROPRIETARY, HIGH-TENSION, CABLE MEDIAN BARRIER
TRP-03-272-13	MGSSYP-1, 2	2011	2012-09	MwSPF	Y	MIDWEST GUARDRAIL SYSTEM (MGS) WITH SOUTHERN YELLOW PINE POSTS
TRP-03-258-12	4CMBLT-1	2009	2012-11	MwSPF	Y	EVALUATION OF A NON-PROPRIETARY, HIGH-TENSION, FOUR CABLE MEDIAN BARRIER ON LEVEL TERRAIN
TRP-03-264-12		2009	2012-11	WSDOT	Y	DEVELOPMENT OF A DESIGN PROCEDURE FOR CONCRETE TRAFFIC BARRIER ATTACHMENTS TO BRIDGE DECKS UTILIZING EPOXY CONCRETE ANCHORS
TRP-03-271-12		2011	2012-12	NebDR	Y	DYNAMIC TESTING OF MGS W6X8.5 POSTS AT DECREASED EMBEDMENT
TRP-03-274-12		2010	2012-12	MwSPF	Y	DETERMINATION OF THE MAXIMUM MGS MOUNTING HEIGHT-PHASE II DETAILED ANALYSIS WITH LS-DYNA
TRP-03-275-12		2010	2012-12	MATC	Y	CABLE MEDIAN BARRIER FAILURE ANALYSIS AND PREVENTION
TRP-03-262-12	MGSNB-1, 2	2011	2013-01	MwSPF	Y	SAFETY PERFORMANCE EVALUATION OF THE NON-BLOCKED MIDWEST GUARDRAIL SYSTEM (MGS)
TRP-03-263-12	NYCC-1,2,3	2010	2013-02	NYS DOT	Y	EVALUATION OF THE NEW YORK LOW-TENSION THREE-CABLE BARRIER ON CURVED ALIGNMENT
TRP-03-254-13		2009	2013-05	MwSPF	Y	COST-EFFECTIVE TREATMENT OF EXISTING GUARDRAIL SYSTEMS
TRP-03-283-13		2010	2013-06	NYDOT	Y	ENERGY ANALYSIS OF VEHICLE-TO-CABLE BARRIER IMPACTS
TRP-03-276-13	MGSMIN-1	2010	2013-08	WSDOT	Y	MINIMUM EFFECTIVE GUARDRAIL LENGTH FOR THE MGS
TRP-03-278-13		2010	2013-08	MwSPF	Y	POST WELD AND EPOXY ANCHORAGE VARIATIONS FOR W-BEAM GUARDRAIL ATTACHED TO LOW-FILL CULVERTS
TRP-03-279-13	WIDA-1,2	2010	2013-10	Wisc	Y	DOWNSTREAM ANCHORING REQUIREMENTS FOR THE MIDWEST GUARDRAIL SYSTEM
TRP-03-277-14		2011	2014-02	MwSPF	Y	SAFETY PERFORMANCE EVALUATION OF WEAK-POST, W-BEAM GUARDRAIL ATTACHED TO CULVERT
TRP-03-292-13		2011	2014-03	Wisc	Y	ZONE OF INTRUSION FOR PERMANENT 9.1-DEGREE SINGLE-SLOPE CONCRETE BARRIERS
TRP-03-294-14		2012	2014-03	MwSPF	Y	DYNAMIC TESTING OF A NON-PROPRIETARY, HIGH-TENSION, CABLE END TERMINAL SYSTEM
TRP-03-295-14	RDTCB-1,2	2009	2014-03	Wisc	Y	DEVELOPMENT OF A RETROFIT, LOW-DEFLECTION, TEMPORARY CONCRETE BARRIER SYSTEM
TRP-03-296-14		2010	2014-03	Wisc	Y	EXTENDING TL-2 SHORT-RADIUS GUARDRAIL TO LARGER RADII
TRP-03-288-14		2012	2014-04	MwSPF	Y	UNIVERSAL BREAKAWAY STEEL POST FOR OTHER APPLICATIONS
TRP-03-291-14	MWTC-1,2,3	2012	2014-06	MwSPF	Y	DYNAMIC EVALUATION OF MGS STIFFNESS TRANSITION WITH CURB
TRP-03-300-14		2012	2014-06	NDR+	Y	DEVELOPMENT OF A MASH TL-3 TRANSITION BETWEEN GUARDRAIL AND PORTABLE CONCRETE BARRIERS
TRP-03-298-14		2008	2014-07	MwSPF	Y	DEVELOPMENT OF A SOCKETED FOUNDATION FOR THE MIDWEST WEAK POST (MWP) V1
TRP-03-284-14		2011	2014-08	WISC	Y	PHASE I ASSESSMENT OF GUARDRAIL LENGTH-OF-NEED
TRP-03-269-14		2011	2014-10	WISC	Y	ROADSIDE GRADING GUIDANCE PHASE II
TRP-03-310-14		2012	2014-12	MwSPF	Y	INCREASED SPAN LENGTH FOR THE MGS LONG-SPAN GUARDRAIL SYSTEM
TRP-03-293-15		2008	2015-04	MwSPF	Y	DEVELOPMENT OF SOCKETED FOUNDATIONS FOR S3X5.7 POSTS
TRP-03-313-15		2012	2015-06	MwSPF	Y	CABLE-TO-POST ATTACHMENTS FOR A NON-PROPRIETARY HIGH-TENSION CABLE BARRIER - PHASE II